

**MULTI-USE TRAIL TYPICAL SECTION 1**

N.T.S.

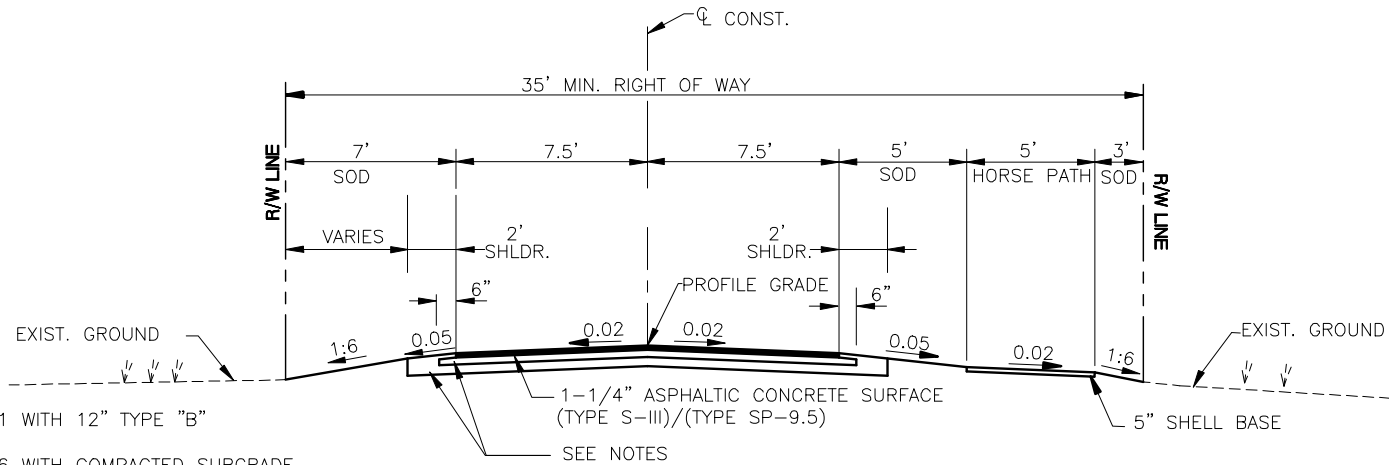

**MULTI-USE TRAIL TYPICAL SECTION 2**

N.T.S.

NOTES:

1. OPTIONAL BASE GROUP 1 WITH 12" TYPE "B" STABILIZATION LBR 40.
2. OPTIONAL BASE GROUP 6 WITH COMPACTED SUBGRADE.
3. ALL DIMENSIONS SHOWN ARE MINIMUM.
4. SEE APPROPRIATE SECTION OF TECHNICAL MANUAL FOR DESIGN PARAMETERS.

REVISION DATE :

**TRANSPORTATION TECHNICAL  
MANUAL**



**MULTI-USE TRAILS  
TYPICAL SECTIONS**

DRAWING NO. TS-2

SHEET NO. 1 OF 1